

080-1

PLATE HEAT EXCHANGER FRAME

"Building the best, servicing the rest"™

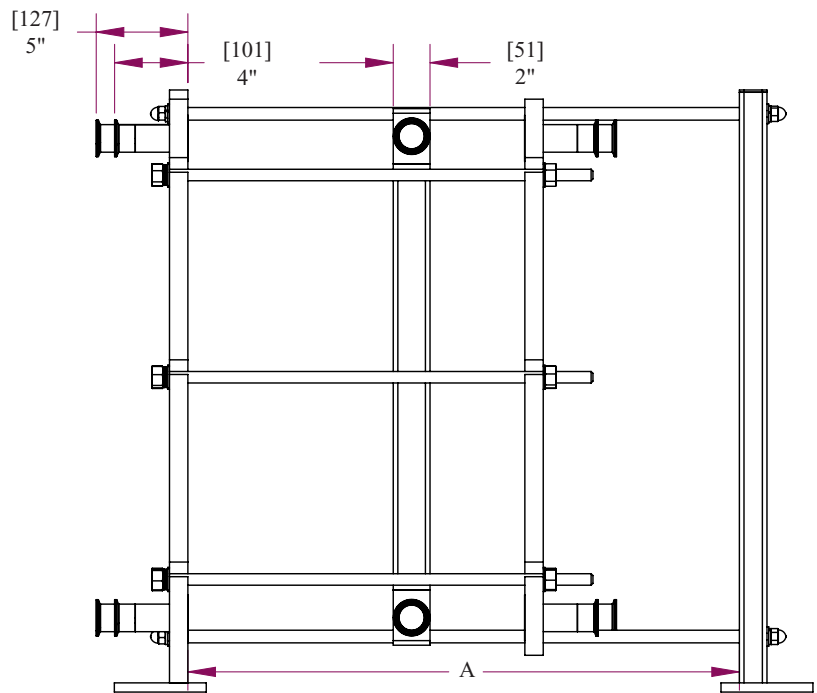
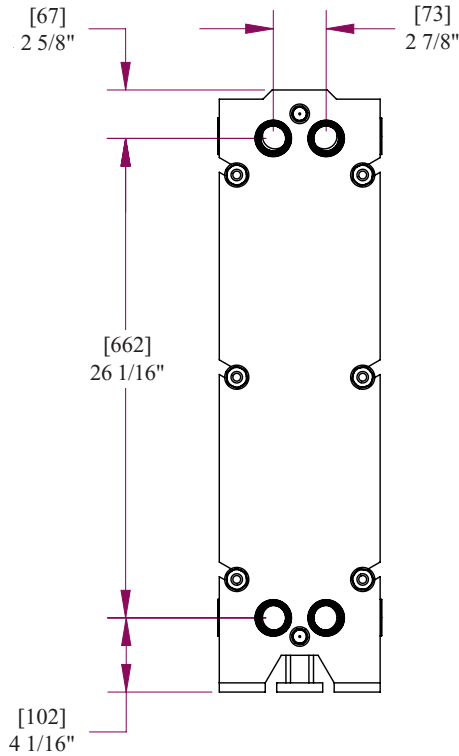

GENERAL INFORMATION

Plate and Gasket Weight:	1.3 lbs / .59 kg
Plate Capacity:	0.05 US Gallons / .19L
Heat Transfer Area:	0.86 ft ² / .08 m ²
Plate Thickness:	0.6mm
Frame Weight: (according to size)	170 - 190 lbs / 77 - 86 kg
Standard Frame Connections:	1 1/2" Sanitary Clamp
Terminal Connections:	1 1/2" Sanitary Clamp
Terminal Weight:	28 lbs / 12.8 kg

FRAME SIZE	FOOT CENTERS [L]	RAIL LENGTH [A]	PLATE CAPACITY
1	24 1/2" [622]	18" [457]	50
2	36 1/2" [927]	30" [762]	130
3	48 1/2" [1232]	42" [1067]	210

Dimensions not to be used for construction

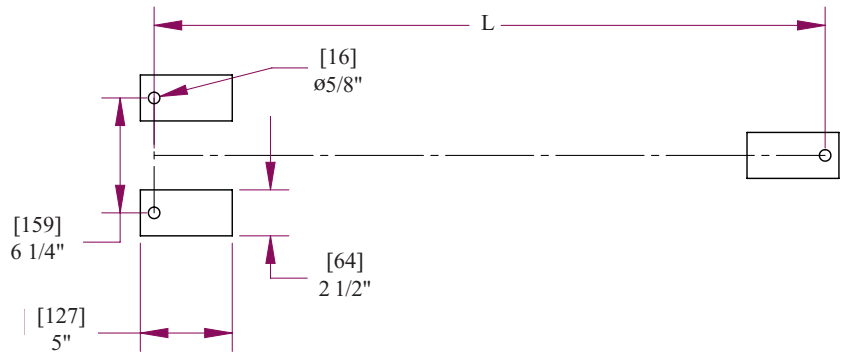

This drawing is the confidential property of AGC HEAT TRANSFER and it must not be reproduced in any form without written consent



Western
9109 SE 64th Ave.
Portland, OR 97206
503.774.7342
800.715.8820
FAX 503.774.2550

Central
1325 Remington Rd.
Suite T
Schaumburg, IL 60173
847.301.6890
FAX 503.774.2550

Eastern
10129 Piper Lane
Bristow, VA 20136
703.257.1660
800.825.8820
FAX 703.330.7940

